

AMIS-30600

LIN Transceiver

General Description

The single-wire transceiver AMIS-30600 is a monolithic integrated circuit in a SOIC-8 package. It works as an interface between the protocol controller and the physical bus.

The AMIS-30600 is especially suitable to drive the bus line in LIN systems in automotive and industrial applications. Further it can be used in standard ISO9141 systems.

In order to reduce the current consumption the AMIS-30600 offers a stand-by mode. A wake-up caused by a message on the bus pulls the INH-output high until the device is switched to normal operation mode.

The transceiver is implemented in I2T100 technology enabling both high-voltage analog circuitry and digital functionality to co-exist on the same chip.

The AMIS-30600 provides an ultra-safe solution to today's automotive in-vehicle networking (IVN) requirements by providing unlimited short circuit protection in the event of a fault condition.

Features

- 1.01 LIN-Bus Transceiver
 - ◆ LIN compliant to specification rev. 1.3 and rev. 2.0
 - ◆ I2T high-voltage technology
 - ◆ Bus voltage ± 40 V
 - ◆ Transmission rate up to 20kbaud
 - ◆ SOIC-150-8 package
- 1.02 Protection
 - ◆ Thermal shutdown
 - ◆ Indefinite short circuit protection to supply and ground
- Load dump protection (45 V)
- 1.03 Power Saving
 - ◆ Operating voltage = 4.75 to 5.25 V
 - ◆ Power down supply current < 50 μ A
- 1.04 EMS Compatibility
 - ◆ Integrated filter and hysteresis for receiver
- 1.05 EMI Compatibility
 - ◆ Integrated slope control for transmitter
 - ◆ Slope control dependant from Vbat to enable maximum capacitive load
- These are Pb-Free Devices

*For additional information on our Pb-Free strategy and soldering details, please download the ON Semiconductor Soldering and Mounting Techniques Reference Manual, SOLDERRM/D.



ON Semiconductor®

<http://onsemi.com>

PIN ASSIGNMENT

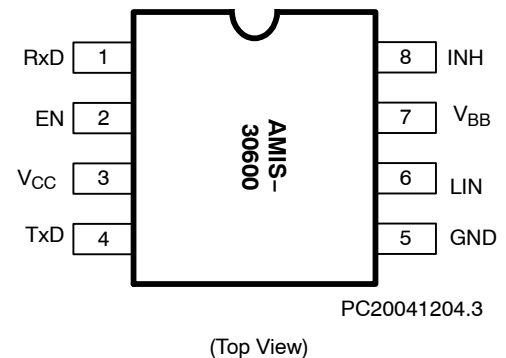

ORDERING INFORMATION

See detailed ordering and shipping information in the package dimensions section on page 9 of this data sheet.

AMIS-30600

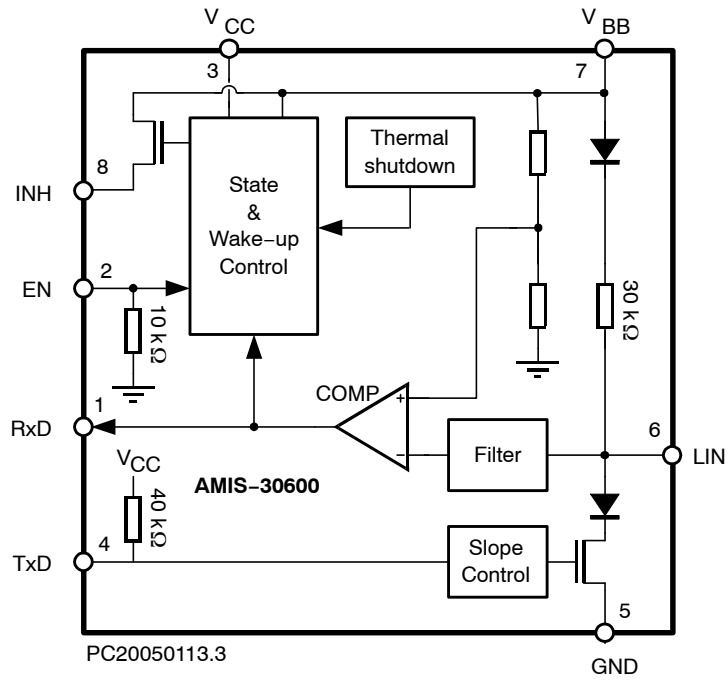

Figure 1. Block Diagram

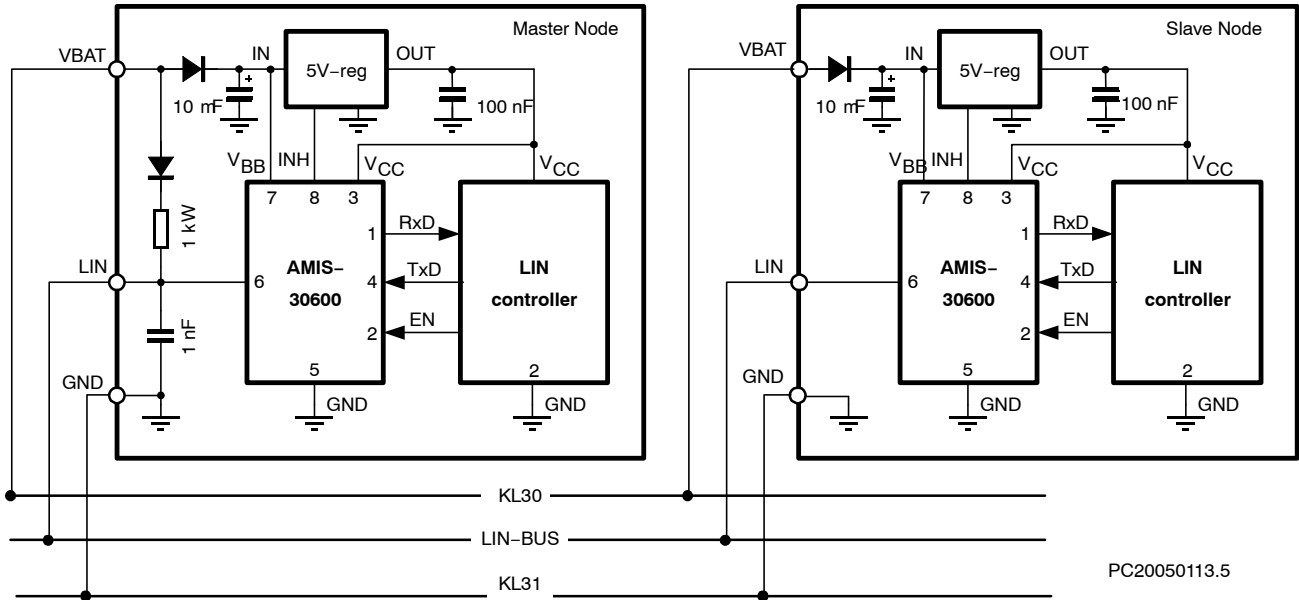

Figure 2. Application Diagram

Table 1. PIN LIST AND DESCRIPTIONS

Pin	Name	Description
1	RxD	Receive data output; low in dominant state
2	EN	Enable input; transceiver in normal operation mode when high
3	VCC	5V supply input
4	TxD	Transmit data input; low in dominant state; internal 40 kΩ pullup
5	GND	Ground
6	LIN	LIN bus output/input; low in dominant state; internal 30 kΩ pullup
7	VBB	Battery supply input
8	INH	Inhibit output; to control a voltage regulator; becomes high when wake-up via LIN bus occurs

Table 2. ABSOLUTE MAXIMUM RATINGS

Symbol	Parameter	Conditions	Min	Max	Unit
V _{CC}	Supply Voltage		-0.3	+7	V
V _{BB}	Battery Supply Voltage		-0.3	+40	V
V _{LIN}	DC Voltage at Pin LIN	0 < V _{CC} < 5.50 V; (Note 1)	-40	+40	V
V _{INH}	DC Voltage at Pin INH	0 < V _{CC} < 5.50 V	-0.3	V _{BB} + 0.3	V
V _{TxD}	DC Voltage at Pin TxD	0 < V _{CC} < 5.50 V	-0.3	V _{CC} + 0.3	V
V _{RxD}	DC Voltage at Pin RxD	0 < V _{CC} < 5.50 V	-0.3	V _{CC} + 0.3	V
V _{EN}	DC Voltage at Pin EN	0 < V _{CC} < 5.50 V	-0.3	V _{CC} + 0.3	V
V _{esd(LIN)}	Electrostatic Discharge Voltage at LIN Pin	(Note 2)	-4	+4	kV
V _{esd}	Electrostatic Discharge Voltage at All Other Pins	(Note 2)	-4	+4	kV
V _{tran(LIN)}	Transient Voltage at Pin LIN	(Note 3)	-150	+150	V
V _{tran(VBB)}	Transient Voltage at Pin V _{BB}	(Note 4)	-150	+150	V
T _{amb}	Ambient Temperature		-40	+150	°C

Stresses exceeding Maximum Ratings may damage the device. Maximum Ratings are stress ratings only. Functional operation above the Recommended Operating Conditions is not implied. Extended exposure to stresses above the Recommended Operating Conditions may affect device reliability.

1. 80 V Version available, contact sales for details.
2. Standardized Human Body Model system ESD pulses in accordance with IEC 1000.4.2.
3. Applied transient waveforms in accordance with "ISO 7637 parts 1 & 3", capacitive coupled test pulses 1 (-100 V), 2 (+100 V), 3a (-150 V), and 3b (+150 V). See Figure 8.
4. Applied transient waveforms in accordance with "ISO 7637 parts 1 & 3", direct coupled test pulses 1 (-100 V), 2 (+75 V), 3a (-150 V), 3b (+150 V), and 5 (+80 V). See Figure 8.

Table 3. OPERATING RANGE

Symbol	Parameter	Min	Typ	Max	Unit
V _{CC}	Supply Voltage	4.75		+5.25	V
V _{BB}	Battery Supply Voltage	7.3		+18	V
T _J	Maximum Junction Temperature	-40		+150	°C
T _{jsd}	Thermal Shutdown Temperature	+150	+170	+190	°C
R _{thj-a}	Thermal Resistance Junction-to-Ambient		185		°C/W

APPLICATION INFORMATION

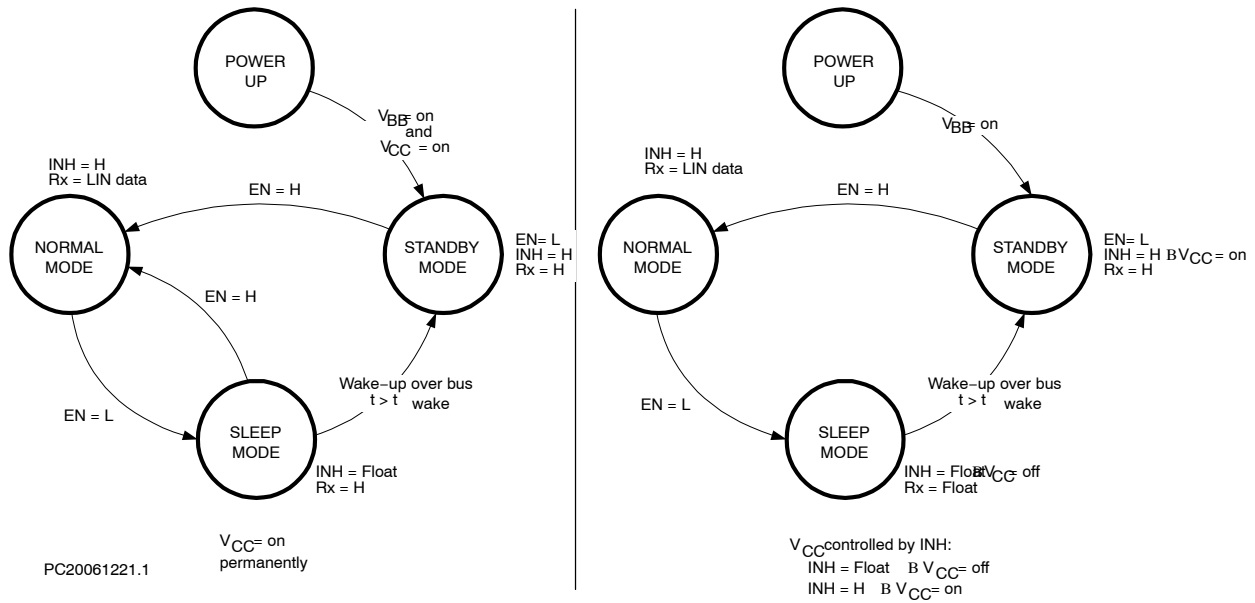

Figure 3. State Diagrams

The AMIS-30600 has a slope which depends of the supply V_{bat} . This implementation guarantees biggest slope-time under all load conditions. The rising slope has to be slower than the external RC-time-constant, otherwise the slope will be terminated by the RC-time-constant and no longer by the internal slope-control. This would affect the symmetry of the bus-signal and would limit the maximum allowed bus-speed.

A capacitor of 10 μF at the supply voltage input V_B buffers the input voltage. In combination with the required reverse polarity diode this prevents the device from detecting power down conditions in case of negative transients on the supply line.

In order to reduce the current consumption, the AMIS-30600 offers a sleep operation mode. This mode is selected by switching the enable input EN low (see Figure 4).

An external voltage regulator can be controlled via the INH output in order to minimize the current consumption of the whole application in sleep mode (see Figure 2). A wake-up caused by a message on the communication bus automatically enables the voltage regulator by switching the INH output high (see Figure 3). In case the voltage regulator control input is not connected to the INH output, or the microcontroller is active respectively, the AMIS-30600 can be set in normal operation mode by EN = H (see Figure 3).

AMIS-30600

Table 4. DC CHARACTERISTICS $V_{CC} = 4.75\text{ V to }5.25\text{ V}$; $V_{BB} = 7.3\text{ V to }18\text{ V}$, $V_{EN} < V_{ENon}$, $T_A = -40^\circ\text{C to }+125^\circ\text{C}$; $R_L = 500\ \Omega$ unless specified otherwise. All voltages with respect to ground, positive current flowing into pin, unless otherwise specified.

Symbol	Parameter	Conditions	Min	Typ	Max	Unit
SUPPLY (Pin V_{CC} and Pin V_{BB})						
I_{CC}	5 V Supply Current	Dominant; $V_{TXD} = 0\text{ V}$ Recessive; $V_{TXD} = V_{CC}$		400 250	700 500	μA
I_{BB}	Battery Supply Current	Dominant; $V_{TXD} = 0\text{ V}$ Recessive; $V_{TXD} = V_{CC}$		1 100	1.5 200	mA μA
I_{BB}	Battery Supply Current	Sleep Mode; $V_{EN} = 0\text{ V}$		35	55	μA
I_{CC}	5 V Supply Current	Sleep Mode; $V_{EN} = 0\text{ V}$		0.25	1	μA
TRANSMITTER DATA INPUT (Pin TxD)						
V_{IH}	High-Level Input Voltage	Output Recessive	$0.7 \times V_{CC}$	–	V_{CC}	V
V_{IL}	Low-Level Input Voltage	Output Dominant	0	–	$0.3 \times V_{CC}$	V
$R_{TXD,pu}$	Pullup Resistor to V_{CC}		24		60	k
RECEIVER DATA OUTPUT (Pin RxD)						
V_{OH}	High-Level Output Voltage	$I_{RxD} = -10\text{ mA}$	$0.8 \times V_{CC}$		V_{CC}	V
V_{OL}	Low-Level Output Voltage	$I_{RxD} = 5\text{ mA}$	0		$0.2 \times V_{CC}$	V
ENABLE INPUT (Pin EN)						
$V_{EN,on}$	High-Level Input Voltage	Normal Mode	$0.7 \times V_{CC}$	–	V_{CC}	V
$V_{EN,off}$	Low-Level Input Voltage	Low Power Mode	0	–	$0.3 \times V_{CC}$	V
$R_{EN,pd}$	Pulldown Resistor-to-GND		6	10	15	k
INHIBIT OUTPUT (Pin INH)						
$V_{INH,d}$	High-Level Voltage Drop: $V_{INH,d} = V_{BB} - V_{INH}$	$I_{INH} = -0.15\text{ mA}$		0.5	1.0	V
$I_{INH,lk}$	Leakage Current	Sleep Mode; $V_{INH} = 0\text{ V}$	-5.0	–	5.0	μA
BUS LINE (Pin LIN)						
$V_{bus,rec}$	Recessive Bus Voltage at Pin LIN	$V_{TXD} = V_{CC}$	$0.9 \times V_{BB}$	–	V_{BB}	V
$V_{bus,dom}$	Dominant Output Voltage at Pin LIN	$V_{TXD} = 0\text{ V}$; $V_{BB} = 7.3\text{ V}$ $V_{TXD} = 0\text{ V}$; $V_{BB} = 18\text{ V}$; $R_L = 500\ \Omega$	0	–	1.2 2.0	V
$I_{bus,sc}$	Bus Short-Circuit Current	$V_{bus,short} = 18\text{ V}$	40	85	130	mA
$I_{bus,lk}$	Bus Leakage Current	$V_{CC} = V_{BB} = 0\text{V}$; $V_{bus} = 8\text{ V}$ $V_{CC} = V_{BB} = 0\text{V}$; $V_{bus} = 20\text{ V}$	-400	-200 5	20	μA
R_{bus}	Bus Pullup Resistance; Note 5	$V_{TXD} = 0\text{ V}$	20	30	47	$\text{k}\Omega$
$V_{bus,rd}$	Receiver Threshold: Recessive-to-Dominant		$0.4 \times V_{BB}$	$0.48 \times V_{BB}$	$0.6 \times V_{BB}$	V
$V_{bus,dr}$	Receiver Threshold: Dominant-to-Recessive		$0.4 \times V_{BB}$	$0.52 \times V_{BB}$	$0.6 \times V_{BB}$	V
V_q	Receiver Hysteresis	$V_{bus,hys} = V_{bus,rec} - V_{bus,dom}$	$0.05 \times V_{BB}$	$0.08 \times V_{BB}$	$0.175 \times V_{BB}$	V
V_{WAKE}	Wake-up Threshold Voltage		$0.4 \times V_{BB}$		$0.6 \times V_{BB}$	V

5. Guaranteed by design. The total resistance of the pullup resistor and the serial diode is measured on ATE.

AMIS-30600

Table 5. AC ELECTRICAL CHARACTERISTICS ACCORDING TO LIN V13 $V_{CC} = 4.75\text{ V to }5.25\text{ V}$; $V_{BB} = 7.3\text{ V to }18\text{ V}$, $V_{EN} < V_{ENon}$, $T_A = -40^\circ\text{C to }+125^\circ\text{C}$; $R_L = 500\ \Omega$ unless otherwise specified. Load for slope definitions (typical loads) = [L1] 1 nF 1 k Ω / [L2] 6.8 nF 600 Ω / [L3] 10 nF 500 Ω .

Symbol	Parameter	Conditions	Min	Typ	Max	Unit
t_slope_F	Slope Time Falling Edge; (Note 6)	See Figure 5	4	–	24	μs
t_slope_R	Slope Time Rising Edge; (Note 6)	See Figure 5	4	–	24	μs
t_slope_Sym	Slope Time Symmetry; (Note 6)	t_slope_F – t_slope_R	–8	–	+8	μs
T_rec_F	Propagation Delay Bus Dominant to RxD = Low; (Note 7)	See Figures 4 and 5		2	6	μs
T_rec_R	Propagation Delay Bus Recessive to RxD = High; (Note 7)	See Figures 4 and 5		6	6	μs
t_WAKE	Wake-up Delay Time		30	100	200	μs

6. Guaranteed by design; not measured for all supply/load combinations on ATE.

7. Not measured on ATE.

Table 6. AC ELECTRICAL CHARACTERISTICS ACCORDING TO LIN v2.0 $V_{CC} = 4.75\text{ V to }5.25\text{ V}$; $V_{BB} = 7.3\text{ V to }18\text{ V}$, $V_{EN} < V_{ENon}$, $T_A = -40^\circ\text{C to }+125^\circ\text{C}$; $R_L = 500\ \Omega$ unless otherwise specified. Load for slope definitions (typical loads) = [L1] 1 nF 1 k Ω / [L2] 6.8 nF 600 Ω / [L3] 10 nF 500 Ω .

Symbol	Parameter	Conditions	Min	Typ	Max	Unit
DYNAMIC RECEIVER CHARACTERISTICS ACCORDING TO LIN v2.0						
trx_pdr	Propagation Delay Bus Dominant to RxD = Low; (Note 8)	See Figure 6			6	μs
trx_pdf	Propagation Delay Bus Recessive to RxD = High; (Note 8)	See Figure 6			6	μs
trx_sym	Symmetry of Receiver Propagation Delay	trx_pdr – trx_pdf	–2	–	+2	μs

DYNAMIC TRANSMITTER CHARACTERISTICS ACCORDING TO LIN v2.0

D1	Duty Cycle 1 = $t_{Bus_rec(min)}/(2 \times t_{Bit})$; See Figure 6		0.396		0.5	
D1	Duty Cycle 1 = $t_{Bus_rec(min)}/(2 \times t_{Bit})$; See Figure 6	THRec(max) = $0.744 \times V_{bat}$; THDom(max) = $0.581 \times V_{bat}$; $V_{bat} = 7.0\text{ V to }18\text{ V}$; $t_{Bit} = 50\ \mu\text{s}$ THRec(max) = $0.744 \times V_{bat}$; THDom(max) = $0.581 \times V_{bat}$; $V_{bat} = 7.0\text{ V}$; $t_{Bit} = 50\ \mu\text{s}$; $t_{amb} = -40^\circ\text{C}$	0.366		0.5	
D2	Duty Cycle 2 = $t_{Bus_rec(max)}/(2 \times t_{Bit})$; See Figure 6	THRec(min) = $0.284 \times V_{bat}$; THDom(min) = $0.422 \times V_{bat}$; $V_{bat} = 7.6\text{ V to }18\text{ V}$; $t_{Bit} = 50\ \mu\text{s}$;	0.5		0.581	

8. Not measured on ATE.

AMIS-30600

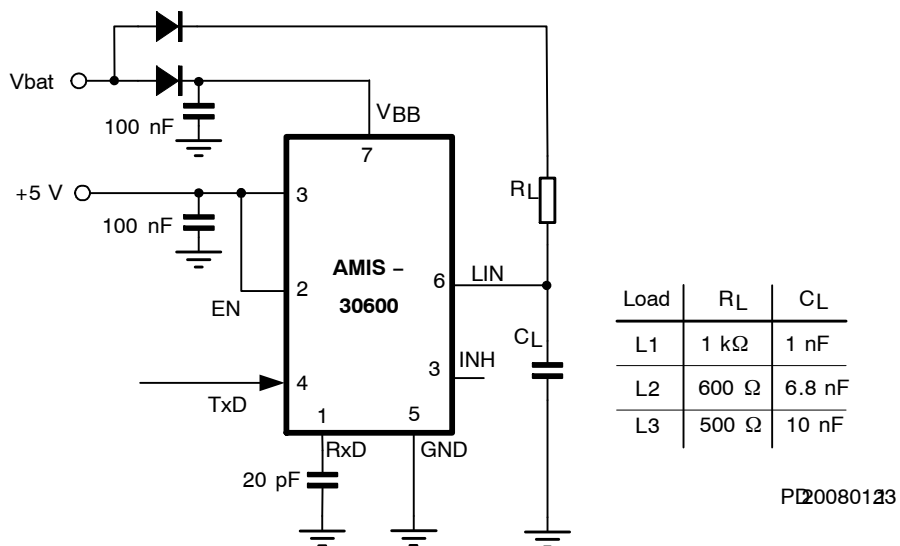

Figure 4. Test Circuit for Timing Characteristics

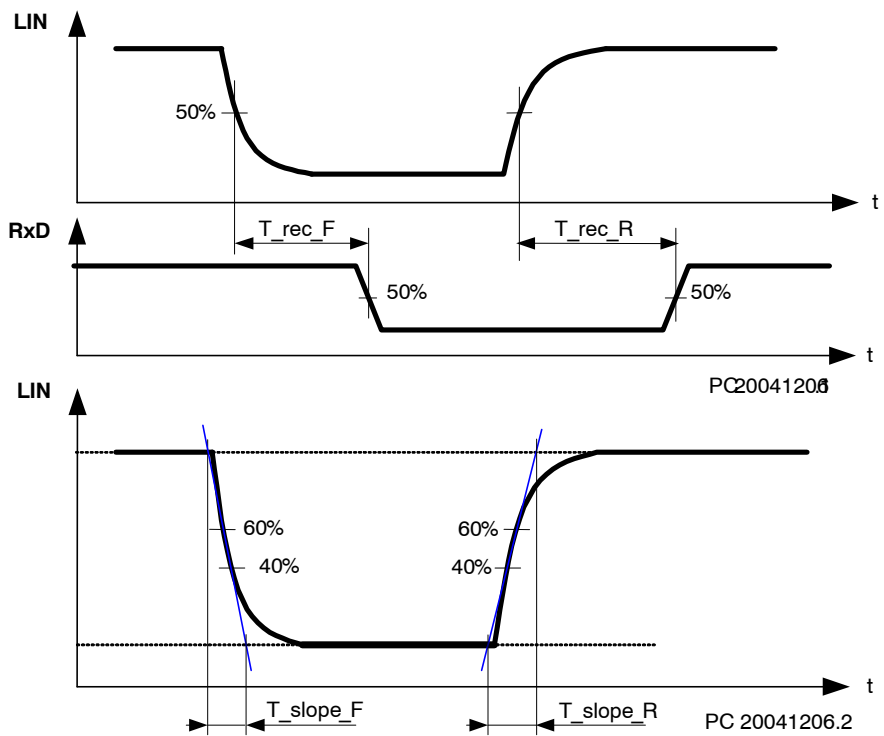

Figure 5. Timing Diagram for AC Characteristics According to LIN 1.3

AMIS-30600

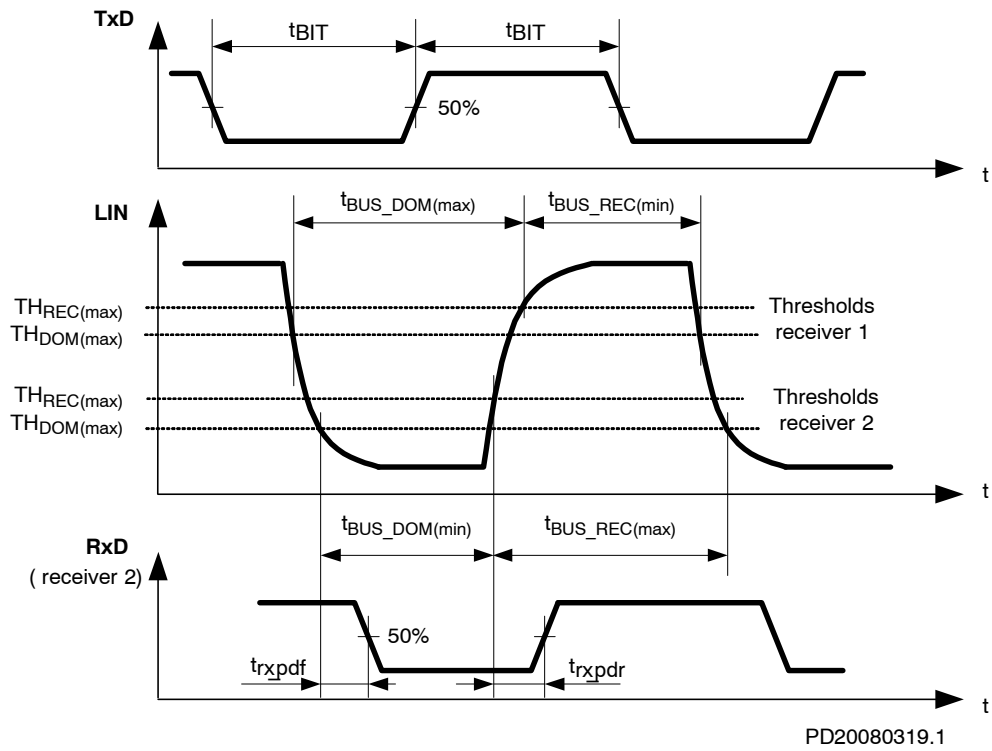

Figure 6. Timing Diagram for AC Characteristics According to LIN 2.0

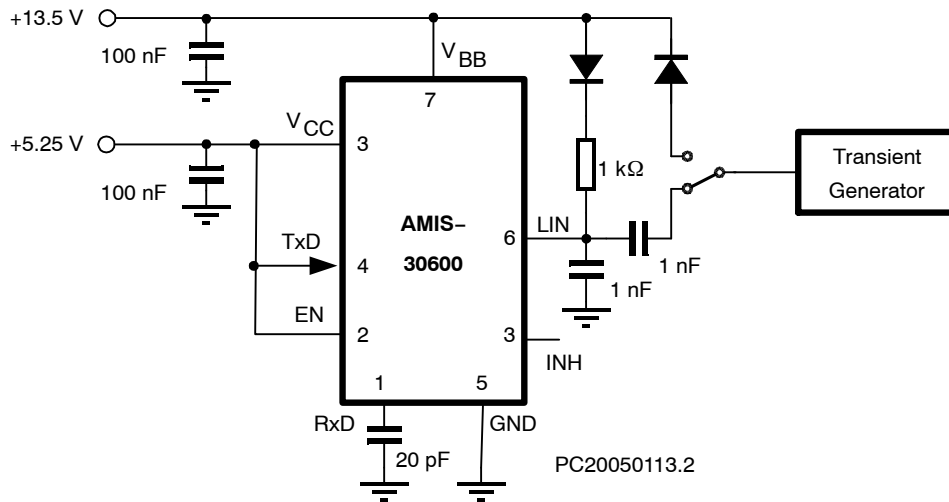

Figure 7. Test Circuit for Transient Measurements

AMIS-30600

DEVICE ORDERING INFORMATION

Part Number	Temperature Range	Package Type	Shipping [†]
AMIS30600LINI1G	-40°C - 125°C	SOIC-8 (Pb-Free)	96 Tube / Tray
AMIS30600LINI1RG	-40°C - 125°C	SOIC-8 (Pb-Free)	3000 / Tape & Reel

[†]For information on tape and reel specifications, including part orientation and tape sizes, please refer to our Tape and Reel Packaging Specifications Brochure, BRD8011/D.

AMIS-30600

PACKAGE DIMENSIONS

SOIC 14
CASE 751AP-01
ISSUE A

DATE 29 AUG 2008

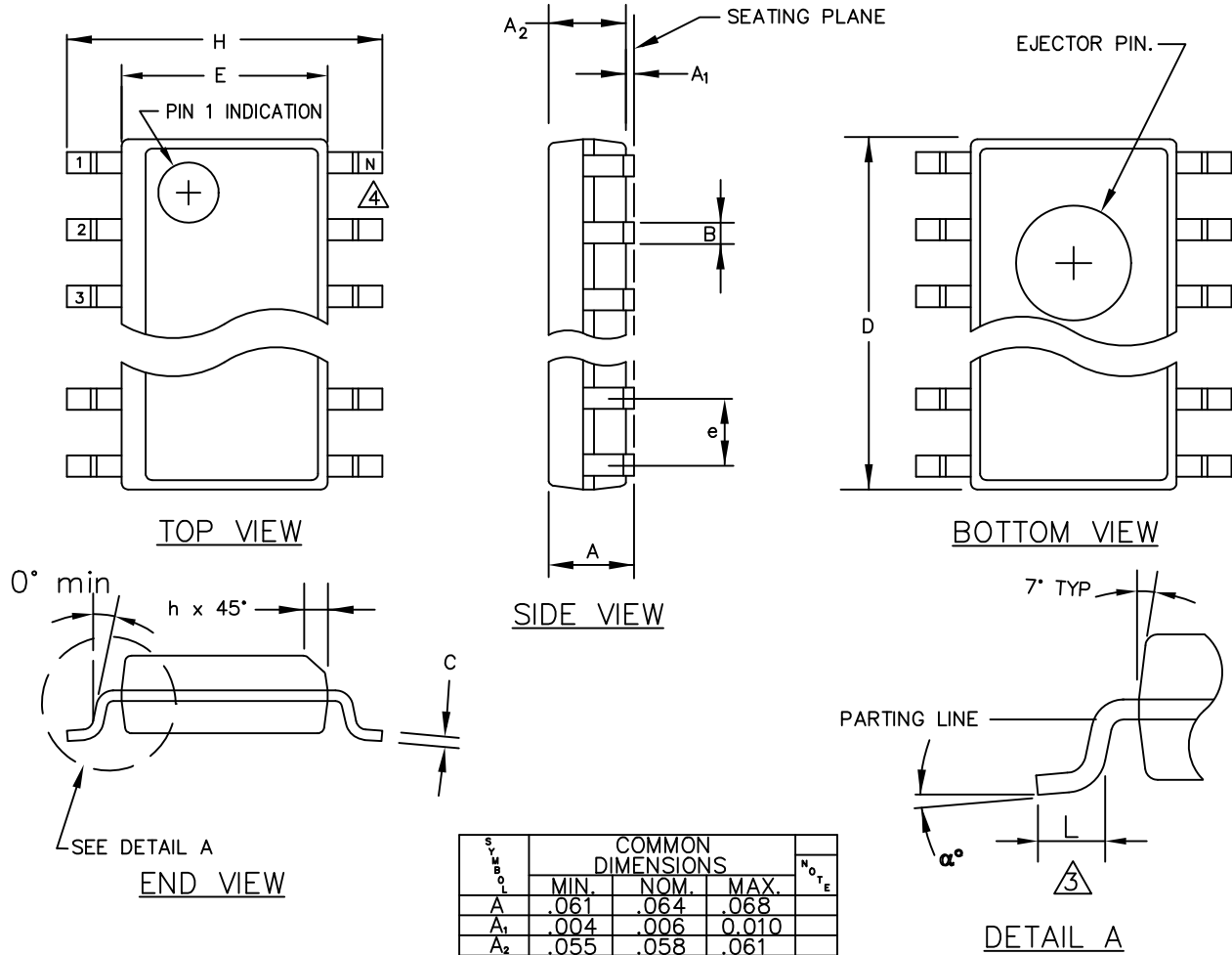

SYMBOL	COMMON DIMENSIONS			NOTE
	MIN.	NOM.	MAX.	
A	.061	.064	.068	
A ₁	.004	.006	0.010	
A ₂	.055	.058	.061	
B	.0138	.016	.020	
C	.0075	.008	.0098	
D	SEE VARIATIONS			1
E	.150	.155	.157	
e	.050 BSC			
H	.230	.236	.244	
h	.010	.013	.016	
L	.016	.025	.035	
N	SEE VARIATIONS			2
α°	0°	5°	8°	

VARIATIONS				NOTE
NOTE	MIN.	NOM.	MAX.	
	1			2
	D			N
AA	.189	.194	.196	8
AB	.337	.342	.344	14
AC	.386	.391	.393	16

ON Semiconductor and  are registered trademarks of Semiconductor Components Industries, LLC (SCILLC). SCILLC reserves the right to make changes without further notice to any products herein. SCILLC makes no warranty, representation or guarantee regarding the suitability of its products for any particular purpose, nor does SCILLC assume any liability arising out of the application or use of any product or circuit, and specifically disclaims any and all liability, including without limitation special, consequential or incidental damages. "Typical" parameters which may be provided in SCILLC data sheets and/or specifications can and do vary in different applications and actual performance may vary over time. All operating parameters, including "Typicals" must be validated for each customer application by customer's technical experts. SCILLC does not convey any license under its patent rights nor the rights of others. SCILLC products are not designed, intended, or authorized for use as components in systems intended for surgical implant into the body, or other applications intended to support or sustain life, or for any other application in which the failure of the SCILLC product could create a situation where personal injury or death may occur. Should Buyer purchase or use SCILLC products for any such unintended or unauthorized application, Buyer shall indemnify and hold SCILLC and its officers, employees, subsidiaries, affiliates, and distributors harmless against all claims, costs, damages, and expenses, and reasonable attorney fees arising out of, directly or indirectly, any claim of personal injury or death associated with such unintended or unauthorized use, even if such claim alleges that SCILLC was negligent regarding the design or manufacture of the part. SCILLC is an Equal Opportunity/Affirmative Action Employer. This literature is subject to all applicable copyright laws and is not for resale in any manner.

PUBLICATION ORDERING INFORMATION

LITERATURE FULFILLMENT:

Literature Distribution Center for ON Semiconductor
P.O. Box 5163, Denver, Colorado 80217 USA
Phone: 303-675-2175 or 800-344-3860 Toll Free USA/Canada
Fax: 303-675-2176 or 800-344-3867 Toll Free USA/Canada
Email: orderlit@onsemi.com

N. American Technical Support: 800-282-9855 Toll Free
USA/Canada
Europe, Middle East and Africa Technical Support:
Phone: 421 33 790 2910
Japan Customer Focus Center
Phone: 81-3-5773-3850

ON Semiconductor Website: www.onsemi.com
Order Literature: <http://www.onsemi.com/orderlit>

For additional information, please contact your local Sales Representative